

3203i

Telescopic Crane



► 3203i Telescopic Crane

With a lifting capacity of 12,000 ft-lb and a vertical lift up to 16' 1" (4.9 m), the 3203i electric telescopic crane by IMT is designed for exceptional performance. Advanced lifting technology makes this crane a powerhouse with the versatility for virtually any application. Yet it's compact in size for the ultimate flexibility and maneuverability on the job site. Cylinder holding valves, 360 degrees of rotation, industrial-grade motors, and more make our 3203i telescopic crane stand up and stand out from the competition.

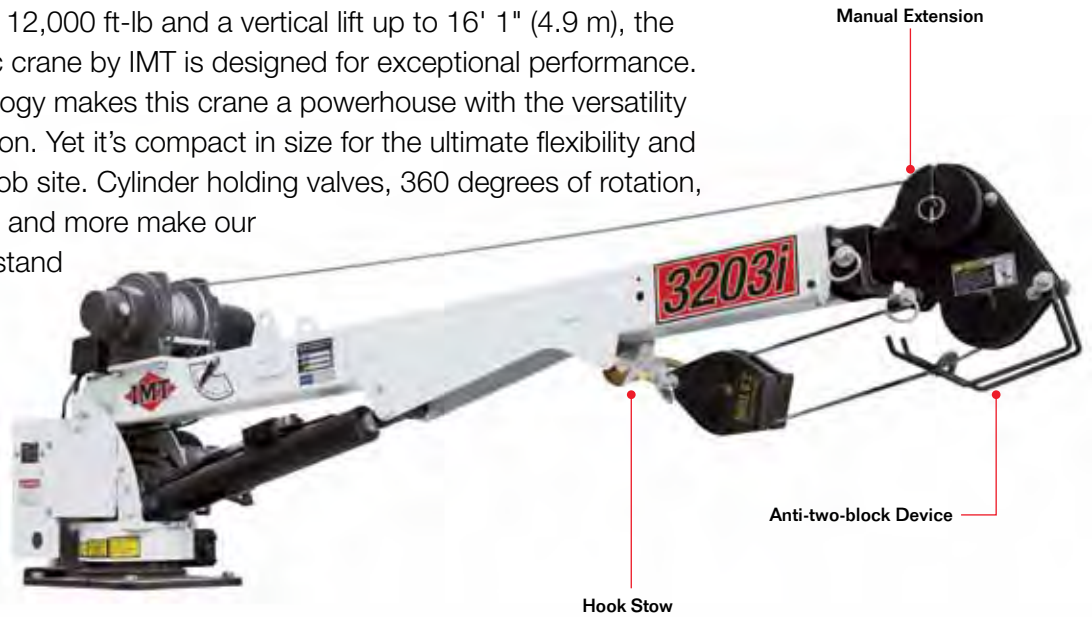

Standard Features

- 12,000 ft-lb (1.6 tm)
- Arc suppression for longer electrical contactor life
- Planetary winches
- On-Off tethered remote control
- Electrical operating systems
- Anti-two-block protection
- Overload shutdown protection
- 25' (7.6 m) power cable
- 25' (7.6 m) remote control pendant
- Boom angle -5° to $+75^\circ$ (-0.1 to 1.3 rad)

Options

- On-Off radio remote control
- Single proportional radio remote control

Body Sizes

- DSC12
- DSC20
- DomCS
- Dominator® I
- Dominator® II

Minimum Chassis Specifications

Chassis Style	Conventional cab
Front Axle Rating (GAWR)	4000 lb (1814 kg)
Rear Axle Rating (GAWR)	7500 lb (3402 kg)
Wheelbase	137" – 161" (348 cm – 409 cm)
Cab-to-Axle	60" – 84" (152 cm – 213 cm)
Resistance to Bending Moment	212,760 in-lb (2452 kg-m)
Frame Section Modulus	5.91 cu in (96.8 cm ³)
Frame Yield Strength	36,000 psi (2482 bar)



On-Off Tethered Remote Control (Standard)

Built tough to perform difficult tasks in the most trying environments, our tethered remote control features a pistol grip handle to increase control, and is ideal for job sites where radio frequency is not allowed.



Optional On-Off Radio Remote Control

Built tough to perform difficult tasks in the most trying environments, our On-Off radio remote control gives you all the features of our tethered remote control, but with the radio remote function that gives you more flexibility and distance.



Optional Single Proportional Radio Remote Control

Our pistol grip single proportional radio remote control decreases hand fatigue while giving you the flexibility and control you need on the job site. Operator-friendly and convenient, it allows you to move closer to the load while lifting.

Specifications

	1-Manual	2-Manual	1-Hydraulic	1-Hydraulic/1-Manual
Crane Rating*	12,000 ft-lb @ 7.5 ft (1.6 tm @ 2.3 m)	12,000 ft-lb @ 7.5 ft (1.6 tm @ 2.3 m)	12,000 ft-lb @ 7.5 ft (1.6 tm @ 2.3 m)	12,000 ft-lb @ 7.5 ft (1.6 tm @ 2.3 m)
Max. Capacity	4000 lb (1814 kg)	4000 lb (1814 kg)	4000 lb (1814 kg)	4000 lb (1814 kg)
Max. Horizontal Reach	11' (3.4 m)	15' (4.6 m)	11' (3.4 m)	15' (4.6 m)
Max. Capacity at Max. Reach	1670 lb (757.5 kg)	1050 lb (476.3 kg)	1670 lb (757.5 kg)	1050 lb (476.3 kg)
Fully Retracted	7' (2.1 m)	7' (2.1 m)	7' (2.1 m)	7' (2.1 m)
Extensions	48" (122 cm) N/A	48" (122 cm) 48" (122 cm)	48" (122 cm) N/A	48" (122 cm) 48" (122 cm)
Lifting Height	12' 1" (3.7 m)	16' 1" (4.9 m)	12' 1" (3.7 m)	16' 1" (4.9 m)
Crane Weight	545 lb (248 kg)	595 lb (270 kg)	585 lb (266 kg)	635 lb (288 kg)
Crane Storage Height	29" (73.7 cm)	29" (73.7 cm)	29" (73.7 cm)	29" (73.7 cm)
Center of Gravity				
Horizontal from centerline of rotation	22.88" (58.1 cm)	22.88" (58.1 cm)	22.88" (58.1 cm)	22.88" (58.1 cm)
Vertical from bottom of crane base	12.75" (32.4 cm)	12.75" (32.4 cm)	12.75" (32.4 cm)	12.75" (32.4 cm)
Required Mounting Space for Crane Base				
	14" x 18" (35.5 cm x 45.7 cm)	14" x 18" (35.5 cm x 45.7 cm)	14" x 18" (35.5 cm x 45.7 cm)	14" x 18" (35.5 cm x 45.7 cm)
Optimum Pump Capacity	1.6 gpm (6 L/min)	1.6 gpm (6 L/min)	1.6 gpm (6 L/min)	1.6 gpm (6 L/min)
Tie-Down Bolt Pattern				
	12" x 12" (30.5 cm x 30.5 cm) and 11.5" x 14.75" (29.2 cm x 37.5 cm)	12" x 12" (30.5 cm x 30.5 cm) and 11.5" x 14.75" (29.2 cm x 37.5 cm)	12" x 12" (30.5 cm x 30.5 cm) and 11.5" x 14.75" (29.2 cm x 37.5 cm)	12" x 12" (30.5 cm x 30.5 cm) and 11.5" x 14.75" (29.2 cm x 37.5 cm)
Rotational Torque	2500 ft-lb (0.4 tm)	2500 ft-lb (0.4 tm)	2500 ft-lb (0.4 tm)	2500 ft-lb (0.4 tm)
Main Boom Elevation Speed	10 sec	10 sec	10 sec	10 sec
Extension Boom Extend Speed	N/A	N/A	10 sec	10 sec
Electrical System Requirements				
	12VDC with two 1000 amp batteries** and 100 amp alternator	12VDC with two 1000 amp batteries** and 100 amp alternator	12VDC with two 1000 amp batteries** and 100 amp alternator	12VDC with two 1000 amp batteries** and 100 amp alternator

*Crane rating (ft-lb) is the rated load (lb) x the respective distance (ft) from the centerline of rotation with all extensions retracted and lower boom in horizontal position.

**The two batteries must be identical in size with maximum cold-crank amp rating of 1000 CCA.

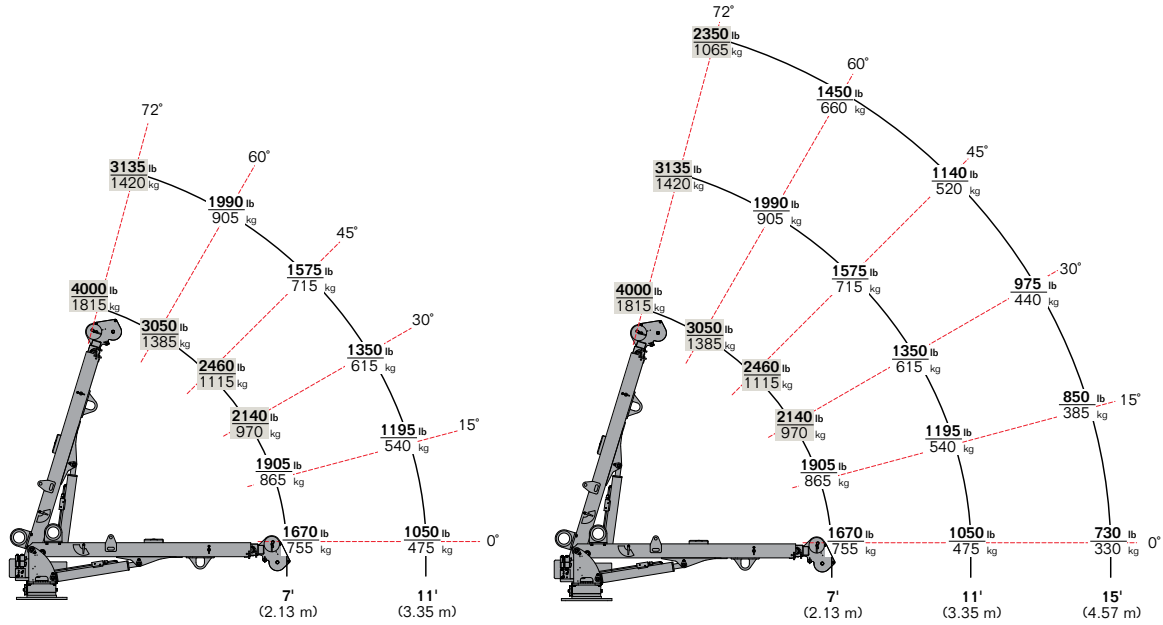
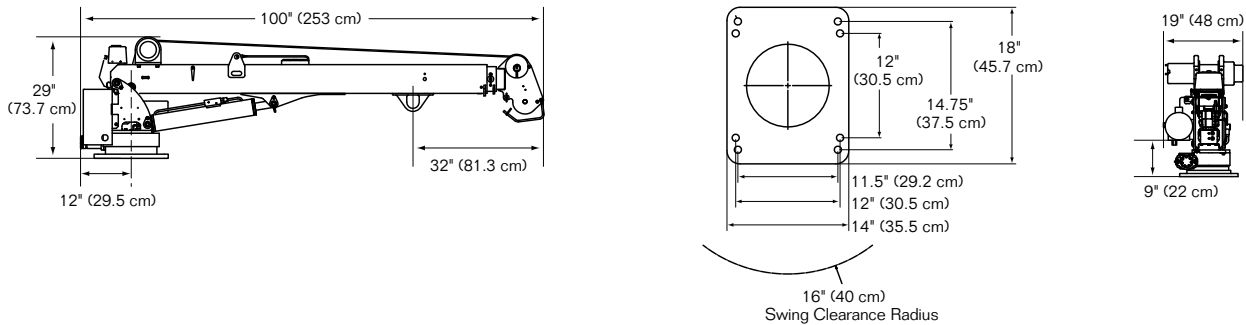

- Maximum one-part line capacity is 2000 lb (907 kg).
- The weight of load-handling devices is part of the load lifted and must be deducted from the rated capacity.

Power Source Options

- Powered by 12-volt battery
- All power features controlled with hand-held remote control

Cylinder Holding Valves

- Safety valves located on lift cylinder and extension cylinder
- Prevent sudden cylinder collapse in the event of hose failure

Rotation System

- Large diameter, self-locking, all-steel worm gear rotation mounted on slewing ring crane bearing
- Worm gear rotation provides 360 degrees continuous power rotation
- Rotation speed is 44 seconds

Hydraulic System

- Self-contained 12-volt hydraulic system supplies 1.6 gpm (6 L/min) @ 2500 psi (172 bar)
- Powered by high-output extended on-time series wound motor

Electrical System

- 100 percent solid-state circuit board with no relays
- Equipped with arc-suppressing circuitry to protect switches and contactors
- Contains entire signal routing logic and overload protection system circuit
- Industrial-grade high-current winch motor and electric/hydraulic pump motor
- No automotive-type solenoids

Overload Protection

- When overloaded, the following functions are stopped: boom down, extension out and winch up
- Protects the operator and crane from overloads

Winch

- 12-volt planetary gear drive winch provides single line speed of 23 fpm (7 m/min) under no-load conditions
- Uses less battery power to operate than worm gear winches
- Equipped with 75' (22.9 m) of ¼" (6.35 mm) diameter 7 x 19 GAC wire rope
- Permanent magnet motor provides immediate stopping for precise load positioning
- Anti-two block prevents the snatch block assembly from coming in contact with boom tip
- Meets ASME B30.5 standards



Nothing Says Commitment Like The Diamond.™

IMT has been meeting the needs of our customers for over 50 years and none of it would have been possible without a distributor network that's second to none. IMT distributors offer fast, knowledgeable service and the ability to help customers find the right product for every application. When you're looking for reliable equipment and dependable service, remember IMT.



An Oshkosh Corporation Company

Iowa Mold Tooling Co., Inc.

500 Highway 18 West
Garner, Iowa 50438
800-247-5958 • www.imt.com

IMT reserves the right to make changes in engineering, design, and specifications; add improvements; or discontinue manufacturing at any time without notice or obligation. IMT, the IMT logo, Dominator and NOTHING SAYS COMMITMENT LIKE THE DIAMOND are registered trademarks or trademarks of Iowa Mold Tooling Co., Inc., Garner, IA, USA.

© 2013 Iowa Mold Tooling Co., Inc. All Rights Reserved.